



Access Technology Ireland

Integrated Security Solutions:

• Gate Automation – Model GHK

Oil-hydraulic gate operator GHK: it is an electro-hydraulic unit fully self contained in that it encloses in itself all the parts for the generation and transmission of the motion to the gate by means of; electric motor, pump and oil distributing valve assembly that allows the shaft to move in and out and therefore to open and close the gate.

Two-way hydraulic locking: it is a device incorporated in the hydraulic circuit in the valve assembly and it can 'lock', i.e. hold the operator shaft (and consequently the gate) in any desired position in either direction open or close. The locking device becomes operational when the electric motor stops; in the event of a power failure, manual operations are possible.



- Networked Access Control Solutions.
- Card / Code Access Systems.
- I.D. Badge Systems.
- Traffic Barriers.
- Coin / Token Car Parking.
- Turnstiles.

Key Features

- Two-way locking in open and close directions.
- Extruded anodised aluminium cover.
- Chromium treated steel piston.
- Complete choice of control; local or remote pushbutton, card access, vehicle ID systems, remote transmitter units, keyswitch, programmable timelock etc.
- Manual release valve on the hydraulic pump enables the post to be operated in the event of a power failure.
- Ease of maintenance – minimum time / cost.

- Gate Automation.
- Automatic Door Operators.
- Electric Locking.
- C.C.T.V.
- Intercom Systems.



design, installation and commissioning of integrated security systems.

General Specification

- Electric Motor.
- Horse power – 0.25 HP (0.18 Kw).
- R.P.M. – 1350.
- Voltage – 220 V / 240 V.
- Absorbed current – 1.2A.
- Oil-Hydraulic Piston.
- Piston shaft – 20 mm.
- No. of operations / open / close – 80/h.
- Working pressure – 10 Bars (1 MPa).
- Working temperature – -25°C +80°C.

Options and Accessories

- Safety vehicle induction loops, traffic light systems, access control, audio systems, etc.
- Radio transmitters / receiver facility to allow remote (e.g. in-car) operation.
- Card access / token reader / intercom mounting posts in complementary designs.
- Mounted warning lights.
- Electronic Programmer.

Technical Specification

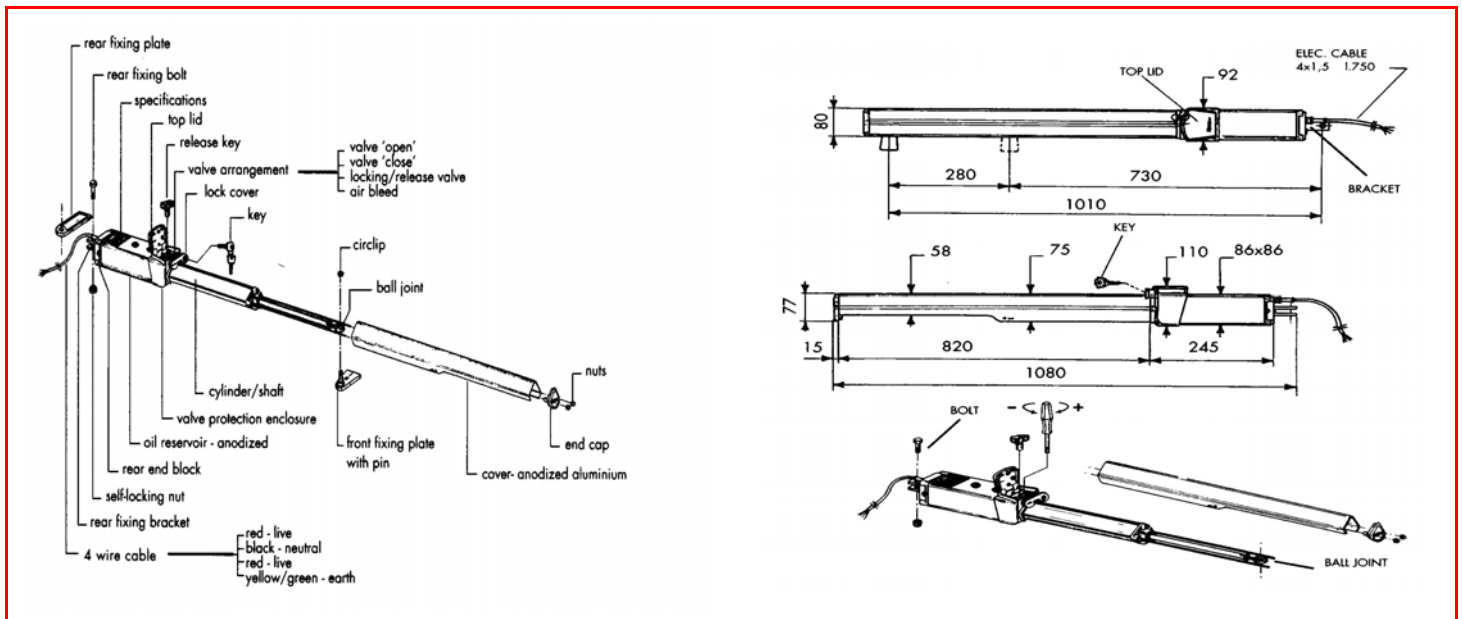

Belfast Office:

A.T.(Ireland) Ltd
24 Mallusk Enterprise Park
Newtownabbey
Co. Antrim
BT36 4GN

Tel: +44 (0)28 9083 6622
Fax: +44 (0)28 9084 4588

Website: <http://www.atireland.co.uk>

E-mail: office@atireland.co.uk

Dublin Office:

A.T.(Ireland) Ltd
9 Ashford Downs
Ashford
Co. Wicklow

Freephone: 1800 284283
Tel: 0404 42041
Fax: 048 9084 4588