



# Access Technology Ireland

## *Integrated Security Solutions:*

### • Turnstiles – Model PTR

The PTR Tripod turnstile couples an elegant, aesthetically pleasing design, with solid practical construction – giving customers a compact, off-the-shelf package for virtually any application.

Already installed in many Blue Chip corporate receptions and public facilities, the PTR features a simple and reliable construction and uncompromising aesthetics. All in all, adding up to an extremely high quality product which will give many years of reliable operation.

Available as wall mounted or free standing, the PTR design encompasses many of the best features of **Ati's** high quality bespoke products. Available in an optional range of colours to match individual customer interior designs, the PTR is the ideal solution where there is a need



• Networked Access Control Solutions.

• Card / Code Access Systems.

• I.D. Badge Systems.

• Traffic Barriers.

• Coin / Token Car Parking.

• Turnstiles.

• Gate Automation.

## **Key Features**

- Compact yet effective – allowing throughput to be controlled with only minimum supervision.
- Proven design and construction from the highest quality materials to give total reliability.
- Elegant – cost effective but suited to most stylish interior reception areas.
- Flexible – mechanical or electrical operation, uni or bi-directional, allow any configuration.
- Designed for high flow revenue collection and / or membership verification.
- Complete range of RAL colours or stainless steel to match any decor.

• Automatic Door Operators.



• Electric Locking.

• C.C.T.V.

• Intercom Systems.

*design, installation and commissioning  
of integrated security systems.*

## General Specification

- **ELECTRONICS.**
- Specifically designed control electronics equipped with rotation sensors, interfaces with all access control and membership systems.
- Power supply; 220v AC 50 Hz.
- Power rating; 50VA.
- Environment; 0°C – 45°C for internal use.
- Supplied for external use upon request.
- **CABINET.**
- Metal sheet average gauge; 15/10.
- Mild steel galvanised and powder coated RAL 7032 Flintstone Grey embossed for high resistance.
- Packing dimensions; m 0.4 x 0.5 x 0.6.
- Net weight 30 Kg
- All models have stainless steel top lid.
- **TRIPOD ASSEMBLY.**
- Features a head and a core of die-cast aluminium.
- The head is powder coated black.
- The tripod arm is fabricated of stainless steel AISI 304 tubing, 35mm dia. And is sealed by a polypropylene expansion cap – helping to retain a clean appearance over time.
- **MECHANISM.**
- Die-cast aluminium.
- Self – centring system with all components made of steel for increased reliability.
- Locking system components made of low wear nylon reinforced with fibre-glass.
- All bolts, screws and small parts meet UNI standards
- Equipped with hydraulic damper and manual release keys for smoothness of operation and silent running

## Options and Accessories

- Stainless steel; available in AISI 304 grade polished manually to a satin finish.
- Passage counters.
- Passage indicators.
- Fail safe facility.
- Anti-panic folding arms.
- Special colours from RAL range upon request.

## Technical Specification

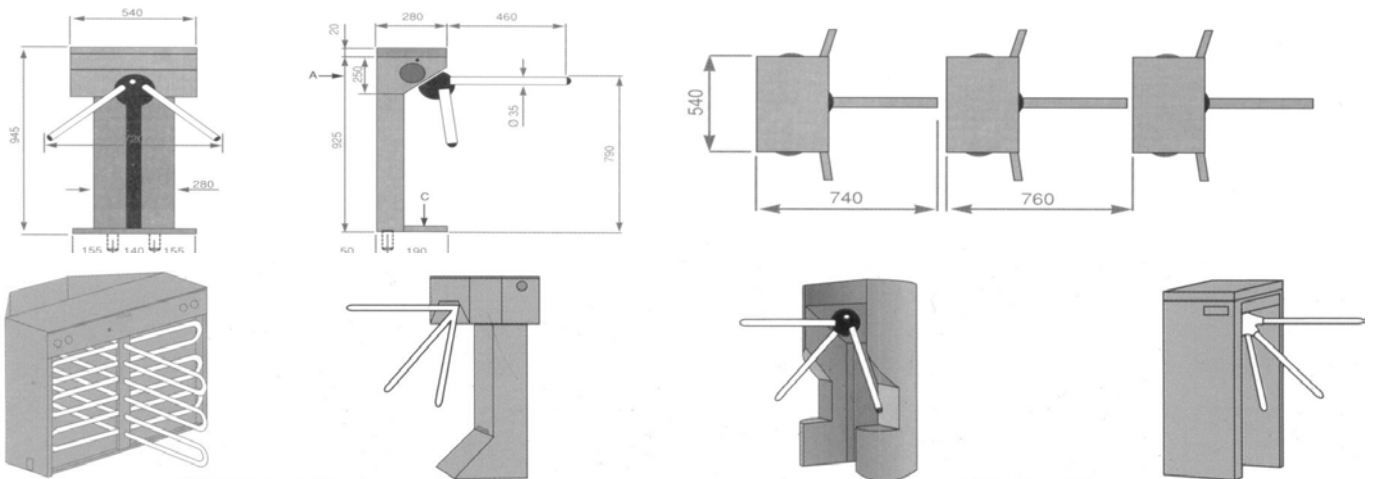

### Belfast Office:

A.T.(Ireland) Ltd  
24 Mallusk Enterprise Park  
Newtownabbey  
Co. Antrim  
BT36 4GN

Tel: +44 (0)28 9083 6622  
Fax: +44 (0)28 9084 4588

Website: <http://www.atireland.co.uk>

E-mail: [office@atireland.co.uk](mailto:office@atireland.co.uk)

### Dublin Office:

A.T.(Ireland) Ltd  
9 Ashford Downs  
Ashford  
Co. Wicklow

Freephone: 1800 284283  
Tel: 0404 42041  
Fax: 048 9084 4588